

„Better Brake Rules“

The U.S. states of California and Washington have passed a new law regarding the environmental sustainability of automotive brake pads, brake linings and brake shoes. Due to this law, which is known as “Better Brake Rules”, manufacturers of brake friction materials are required to register their products.

For California it means, with effect from 1st of January 2014, mentioned products which were manufactured from this date on, need an environmental code on the product to be distributed.

With effect from 1st of January 2015 the state of Washington requires the marking of products and the marking of packaging (label) as well.

The environmental code on the product is a combination of the “year of production” and a letter (“A”, “B” or “N”) which indicates the compliance level. This letter will be granted by an officially designated registrar (NSF) based on the test results of an accredited third-party laboratory.

	A	B	N
Copper content	more than 5.00 %	0.50 % - 5.00 %	less than 0.50 %

Example for the marking of a MINTEX brake pad with environmental code:

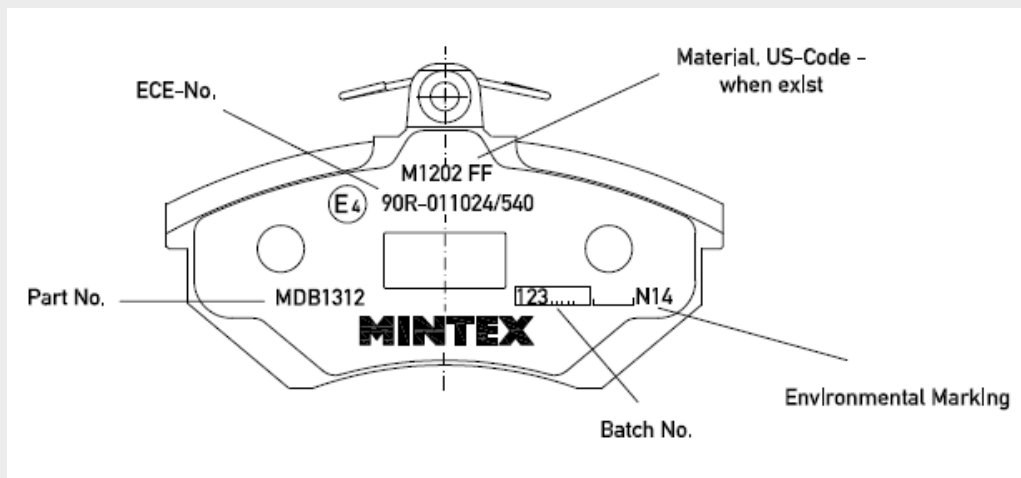

To indicate the compliance level on the packaging, the following images will be used:



To fulfill the requirements of the “Better Brake Rules” regulation, all MINTEX friction products which could probably be sold to the United States of America are already certified and marked with environmental code on the product. During 2014 TMD Friction will gradually add above shown leaf marks to the labels of the relating products, to be in line with the requirements of Washington State.